

RF-RR 24V Powered Routers



Features:

- Proven 802.15.4 low power network
- Allows networks to be expanded

Benefits:

- Self-healing tree topology
- Lower installation costs
- Easy to install and commission

Technical Overview

These routers are used in conjunction with the Sontay RF-RX20 or RF-RX40 receiver units, and RF-RS series of battery powered radio sensors, and are used to route signals from battery powered nodes and other routers to the receiver module, where the signal strength of a direct path is not sufficient for reliable communications.

Note: Each router can support a maximum of 16 'children', which can consist of a maximum of 8 battery powered nodes and 8 routers, or up to 16 routers if there are no battery powered nodes. Consideration should be given to network planning for redundancy in case of router failure or damage.

Routers automatically find the best path back to the receiver, which may be directly to the receiver or via other 'parent' routers.

Specification:

Part Codes:

Common specification:

Radio Output:	
Frequency	2.4GHz
16 channels, automatically selected	
Direct-sequence spread spectrum	
Compliance	IEEE 802.15.4-2006
Data Encryption	AES 128
Power Output	+10dBm
Power Supply	24Vac/dc
Operating:	
Temperature	-10 to +50°C
RH	0 to 90%, non-condensing
Country of origin	UK

Plant Housing:

Material	ABS (flame retardant type VO)
Dimensions	116 x 106 x 52mm
Protection:	
Snap-shut lid	IP54
	IP65 (see page 4 note 8)
Aerial Characteristics:	
Gain	2.0dBi
VSWR	<2:1

Space Housing:

Material	ABS (flame retardant)
Dimensions	85 x 85 x 23mm
Protection	IP30
Aerial Characteristics:	
Gain	1.2dBi
VSWR	1.5:1

RF-RR-600

Plant housing router

RF-RR-T-900

Space housing router



The products referred to in this data sheet meet the requirements of EU Directive 2004/108/E

How It Works:

Routers are used to route signals from battery powered nodes and other routers to the receiver module, where the signal strength of a direct path is not sufficient for reliable communications.

Data is transmitted back to the receiver at configurable time intervals, or on a configurable change in measured value. Each sensor retains these configurations if the battery becomes discharged or requires replacement.

The routers and receiver automatically select which of the 16 transmission channels available gives the best radio network performance, taking into account both signal strength and interference levels from adjacent channels and equipment (such as Wi-Fi etc.) The routers automatically find the best path back to the receiver, which may be directly to the receiver or via "parent" routers.

NB Each router can support a maximum of 16 "children", a maximum of 8 of which can be battery powered "end devices" and a maximum of which can be 8 routers. Consideration should be given on network planning for redundancy in case of router failure or damage.

Aerial Orientation (plant sensor types);

For best results ensure that the main body of the aerial is vertical.

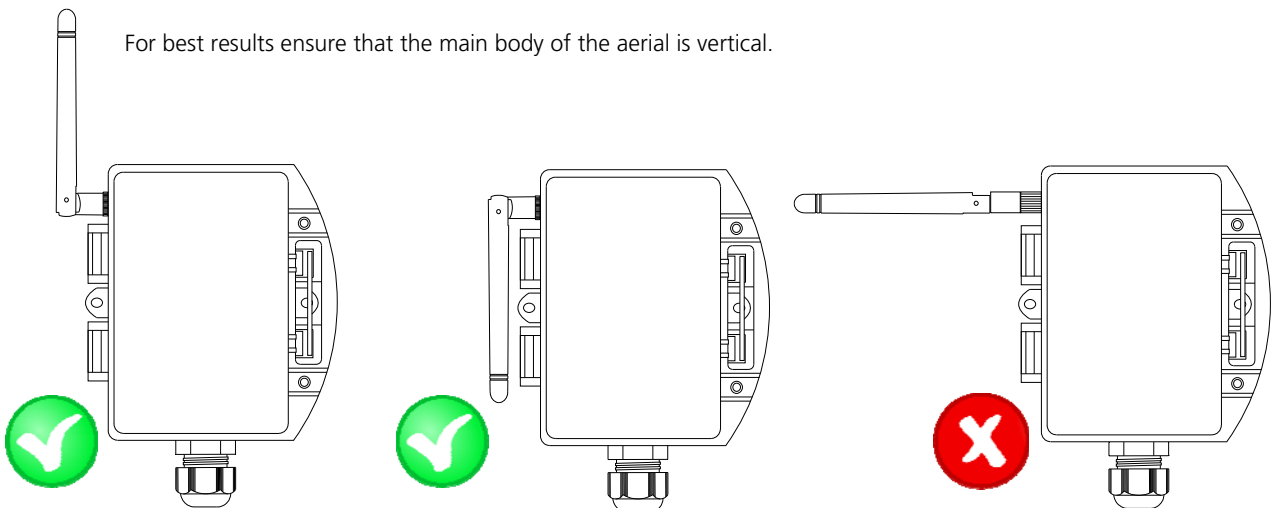

Installation:

Plant Sensor types:

1. Remove all packaging from the sensor.
2. Note the MAC address printed on the affixed label and note where this MAC address is installed.
3. Mount the sensor in the required position (this will have been determined by the site survey tool, (see the quick start guide and manual).
4. It is recommended that the unit be mounted with the cable entry at the bottom. If the cable is fed from above then into the cable gland at the bottom, it is recommended that a rain loop be placed in the cable before entry into the sensor.

Tel: +44 (0)1732 861200. - E-mail: sales@sontay.com. - Web: www.sontay.com.

© 2012 Sontay Limited. All rights reserved

Installation (continued):

5. Release the snap-fit lid by gently squeezing the locking tab and feed the cable through the waterproof gland & terminate the cores at the terminal block. Leaving some slack inside the unit, tighten the cable gland onto the cable to ensure water tightness.
6. Observe correct polarity if using a 24Vdc power supply. To power on the unit, fit J200.
7. Snap shut the lid after the connections have been made if IP65 protection is required, secure the lid with two screws provided.
8. Ensure, at a minimum, that all routers and the receiver on the radio network are powered on, and allow about 5 minutes for the network to auto-commission before attempting to read values or make configuration changes.

Space Sensor Types:

1. Remove all packaging from the sensor.
2. Note the MAC address printed on the affixed label and note where this MAC address is installed.
3. Mount the sensor in the required position (this will have been determined by the site survey tool, (see the quick start guide and manual)).
4. Undo the tamperproof screw at the bottom of the housing and gently pull the front panel from the base.
5. Using the base as a template mark the hole centres and fix to the wall with suitable screws. Alternatively the base plate can be mounted on to a conduit box or a standard recessed back box.
6. Feed cable through the 22mm knockout in the base of the housing and terminate the cores at the terminal block as required. Leaving some slack inside the unit.
7. Observe correct polarity if using a 24Vdc power supply. To power on the unit, fit J200.
8. Replace the housing to the base plate.
9. Re-fit the tamperproof screw through the lug at the bottom of the base plate.
10. Ensure, at a minimum, that all routers and the receiver on the radio network are powered on, and allow about 5 minutes for the network to auto-commission before attempting to read values or make configuration changes.

Whilst every effort has been made to ensure the accuracy of this specification, Sontay cannot accept responsibility for damage, injury, loss or expense from errors or omissions. In the interest of technical improvement, this specification may be altered without notice.

Tel: +44 (0)1732 861200. - **E-mail:** sales@sontay.com. - **Web:** www.sontay.com.

© 2012 Sontay Limited. All rights reserved